

REMARK : RoHS REQUIREMENT APPLIED
(符合RoHS)

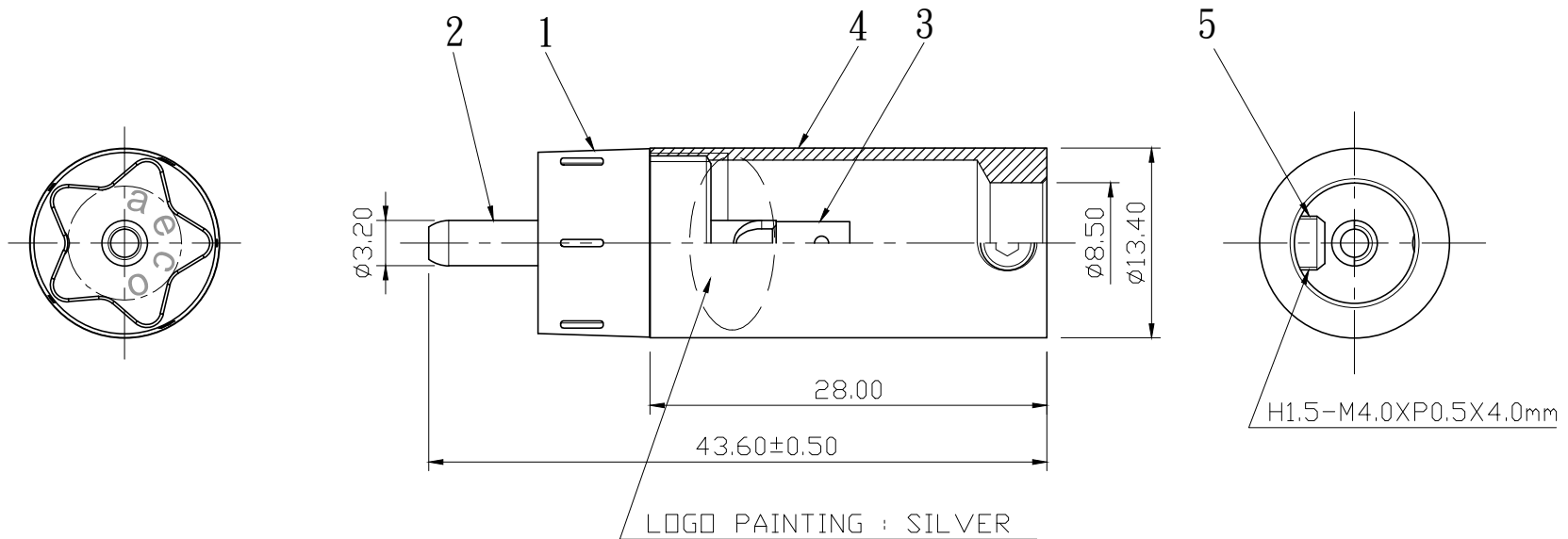

字型請參考樣品
PLEASE REFER TO THE FONT
OF THE SAMPLE

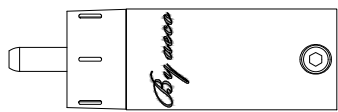

S 1 : 1

Note :
The recommended soldering temperature :
-Use temperature-controlled soldering iron and keep 380°C for about 5~8 seconds.
-Use temperature-controlled soldering iron and keep 360°C for about 9~13 seconds.
-Use temperature-controlled soldering iron and keep 340°C for about 13~18 seconds.
-Use temperature-controlled soldering iron and keep 320°C for about 19~25 seconds.

7						DIMENSIONS ARE IN MILLIMETERS UNLESS OTHERWISE PECIFIED TOLERANCES (一般公差) 0.5~6 = ±0.2 >6~30 = ±0.4 >30~120 = ±0.6 >120~315 = ±1 >315~1000 = ±1.6 ANGLES(角度) = ±5°	CHECKED	 雅鈦企業有限公司 Aec Connectors Co., Ltd.	
6							TITLE		RCA PLUG
5	screw	1	brass	nickel	SCREW-202N-M4XP0.5X4.0mm		DRAWN	DRAWING NO.	ARP-4044ZARD/WERh(Tc)-A-8.5
4	shell	1	brass	zinc alloy			<i>Jim</i>	FILE NO.	DRAWINGAECO\ARP-4044ZARD/WERh(Tc)-A-8.5
3	solder tab	1	copper	rhodium			DATE		
2	contact pin	1	tellurium copper	rhodium			2015. 05. 21		
1	body	1	nylon	red/white					
NO.	Description	Unit	Materials	Finish	Drawing No.	SCALE	2 : 1	UNIT	MM